

Claritac®

X-PRO



1/2" AIR RATCHET WRENCH

MODEL NO: CAT199

PART NO: 3120516

OPERATING & MAINTENANCE INSTRUCTIONS

UK
CA | CE

ORIGINAL INSTRUCTIONS

GC02/22 - Rev 1

INTRODUCTION

Thank you for purchasing this CLARKE Ratchet Wrench which is ideally suited to quick removal and installation of nuts, bolts, and other fasteners where space is limited.

Please read all of the safety and operating instructions carefully before using this product. In doing so you will ensure the safety of yourself and that of others around you, and you can look forward to your purchase giving you long and satisfactory service.

Please keep these instructions in a safe place for future reference.

SPECIFICATION

Model Number	CAT199
Part Number(s)	3120516
Min. Hose Size (ID)	1/4" BSP
Max Operating Pressure	90 psi (6.2 bar)
Air Consumption	4 cfm (max @90psi)
Drive size	1/2" Square
Max No Load Speed	180 rpm @ 90psi
Max Torque	60 ft/lb (85 Nm)
Air Inlet Size	1/4" BSP Female
Sound Pressure Level (LpA dB)	86 dB(A)
Sound Power Level (LwA dB)	97 dB(A)
Vibration Levels	3.78 m/s ² (uncertainty factor K= 1.5m/s ²)
Weight	1.07 kg
Wrench Dimensions (L x W x H)	238 x 53 x 47 mm

Please note that the details and specifications contained herein are correct at the time of going to print. However CLARKE International reserve the right to change specifications at any time without prior notice.

GENERAL SAFETY RULES



CAUTION: FAILURE TO FOLLOW THESE PRECAUTIONS COULD RESULT IN PERSONAL INJURY, AND/OR DAMAGE TO PROPERTY.

THE WORK ENVIRONMENT

1. Keep the work area clean and tidy.
2. Dress appropriately - Do not wear loose clothing or jewellery. Tie long hair out of the way.
3. Keep children and visitors away - Do not let children handle the tool.
4. DO NOT operate the tool where there are flammable liquids or gases.

USE OF AIR POWERED TOOLS

1. Stay alert and use common sense - do not operate the tool when you are tired or under the influence of alcohol, drugs or medication.
2. ALWAYS wear eye protectors when using the tool. Eye protectors must provide protection from flying particles from the front and the side. Ear protectors should also be worn.
3. DO NOT overreach - Keep proper footing and balance at all times.
4. NEVER use oxygen, CO², combustible gases or any type of bottled gas as a source of power for this tool.
5. DO NOT connect the air supply hose with your finger on the trigger.
6. DO NOT exceed the maximum pressure for the tool of 90 psi / 6.2 bar.
7. ALWAYS keep the air hose away from heat, oil and sharp edges.
8. DO NOT fit the air tool to a stand or clamping device that may damage it.
9. Check hoses for leaks or worn condition before use and ensure that all connections are secure.
10. DO NOT use the tool for any purpose than that described in this manual.
11. DO NOT carry out any alterations or modifications to the air tool.
12. ALWAYS disconnect from the air supply when:
 - Performing any maintenance.
 - The air tool is not in use.
 - The air tool will be left unattended.

- Moving to another work area.

13. DO NOT use the air tool if it is defective or operating abnormally.
14. Avoid damaging the air tool for example by applying excessive force of any kind.
15. ALWAYS maintain the air tool with care. Keep it clean for the best and safest performance.
16. Quick change couplings should not be located at the tool. They add weight and could fail due to vibration.
17. DO NOT force or misuse the tool. It will do a better and safer job at the rate for which it was designed.
18. This air tool vibrates with use. Vibration may be harmful to your hands or arms. Stop using the tool if discomfort, a tingling feeling or pain occurs. Seek medical advice before resuming use.
19. DO NOT carry the air tool by the air hose.
20. DO NOT carry the air tool with your finger on the trigger.
21. When not in use the air tool must be disconnected from the air supply and stored in a dry place out of the reach of children.

COMPRESSED AIR REQUIREMENTS



WARNING: COMPRESSED AIR CAN BE DANGEROUS. ENSURE THAT YOU ARE FAMILIAR WITH ALL PRECAUTIONS RELATING TO THE USE OF COMPRESSORS AND COMPRESSED AIR SUPPLY.

A typical air line layout is shown below. If an automatic in-line filter/regulator is used, it will keep air tools in good condition but should be regularly checked and topped up with oil. CLARKE airline oil should be used and the lubricator be adjusted to approx 2 drops per minute.

Use only clean, dry, regulated compressed air as a power source.

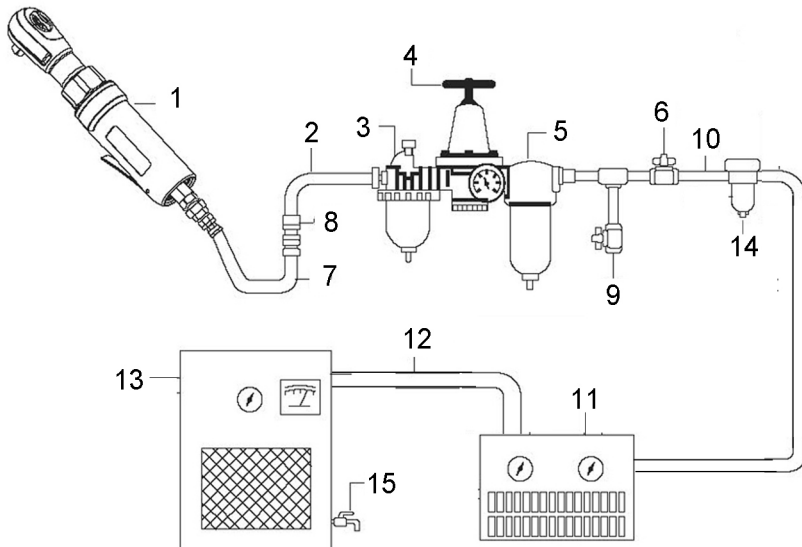

AIR SYSTEM LAYOUT :

- | | |
|-------------------------------|-------------------------------------|
| 1. Air Tool | 9. Drain Valve |
| 2. Air Hose 3/8" (I.D.) | 10. 1/2" Or Larger Pipe And Fitting |
| 3. Oiler | 11. Air Dryer |
| 4. Pressure Regulator | 12. 1" Or Larger Pipe And Fitting |
| 5. Filter | 13. Air Compressor |
| 6. Shut Off Valve | 14. Auto Drain |
| 7. Whip Hose | 15. Drain Valve |
| 8. Coupler Body And Connector | |

Air compressors used with the tool must comply with the appropriate European Community Safety Directives.

The air hose must be rated at least 150% of the maximum operating pressure of the tool.

For optimum performance it is recommended that a 3/8" ID airline hose is used.

A build-up of moisture or oil in the air compressor will accelerate wear and corrosion in the air tool. Ensure any moisture is drained from the compressor daily and the inlet filter is kept clean.

If an unusually long air hose is required, (over 8 metres), the line pressure or the hose inside diameter may need to be increased to maintain air pressure at the tool.

Never exceed the maximum operating pressure for the air tool. It is recommended that air pressure to this tool does not exceed 90 psi (6.2 Bar) at the air tool when running. Higher pressures and dirty air will shorten the life of the tool due to faster wear and is a possible safety hazard.

Check hoses for wear or damage before use.

OVERVIEW

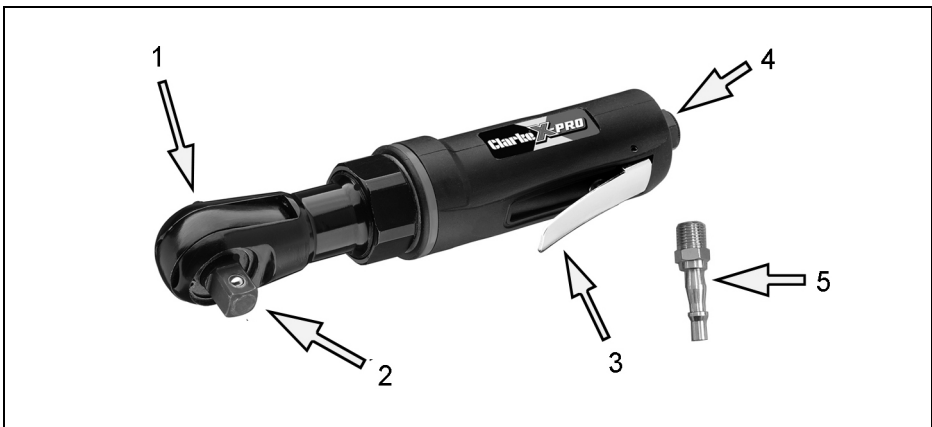

NO	DESCRIPTION	NO	DESCRIPTION
1	Direction Control	4	Airline Inlet
2	1/2" Square Drive	5	Airline adaptor
3	Trigger		

BEFORE USE



WARNING: COMPRESSED AIR CAN BE DANGEROUS. ENSURE THAT YOU ARE FAMILIAR WITH ALL PRECAUTIONS RELATING TO THE USE OF AIR COMPRESSORS AND COMPRESSED AIR SUPPLY.

NOTE: Ensure the compressor is turned off.

1. Remove the travel plug and connect either a suitable hose directly or using the male adaptor supplied.
 2. If required, connect an in-line mini oiler to the tool.
 - A mini oiler helps to prolong the life of any air tool.
 3. If a mini-oiler is not being used, run a few drops of oil through the tool before use. It can be entered through the airline connector or via the hose at the nearest connection to the air supply.
 4. Connect the other end of the hose to the compressor.
 5. Turn on the air supply and check for air leaks. Rectify any found before proceeding. Set the working pressure to 90psi/6.2 bar for best performance
 - PTFE tape may be useful for sealing threaded connections.
- Your air tool is now ready for use.

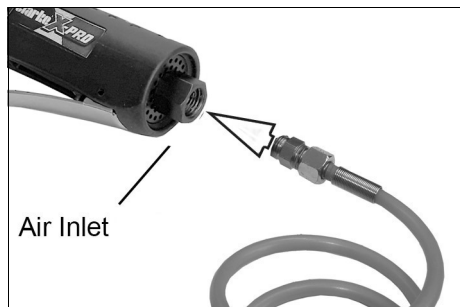
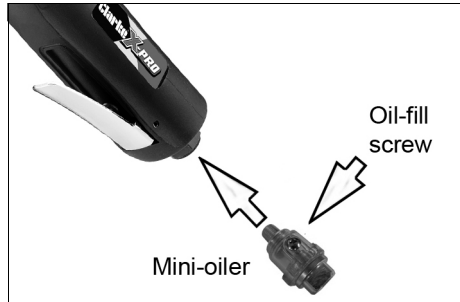

OPERATION

SETTING THE DIRECTION OF ROTATION



WARNING: ALWAYS WAIT UNTIL THE DRIVE SHAFT HAS STOPPED ROTATING BEFORE SETTING THE DIRECTION OF ROTATION.

To select the direction of rotation turn the direction control as follows.

- For tightening bolts/nuts, turn the direction control anti-clockwise to F (Forward).
- For loosening bolts/nuts, turn the direction control clockwise to R (Reverse).



FITTING THE SOCKETS AND USING THE WRENCH

1. Select the socket required and push it onto the square drive shaft.
 - It clicks into place when secure.
2. Place the socket over the nut.
 - Take care that the socket is firmly engaged.
3. Squeeze the trigger against the body of the tool to start.
4. Release the trigger to stop the tool.
5. ALWAYS ensure the tool has stopped before putting it down.
6. When releasing very tight fastenings initially break loose by hand. Squeeze the trigger and the air tool will complete the job.
7. If necessary, use penetrating oil to assist in freeing off rusted fasteners.
8. When assembling, start turning fasteners by hand, then set the rotation forward or reverse. Apply the tool gently and squeeze the trigger to tighten with power.
9. Final tightening should be completed by hand to the required torque values.

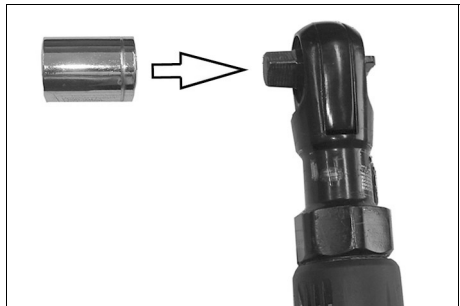

DISCONNECTING THE AIR SUPPLY

1. DO NOT disconnect the air hose until the supply is isolated at a shut-off valve.
2. Once the pressure has been isolated, disconnect the air supply hose from the air tool.
3. Shut down the compressor at the end of the work session and drain daily as recommended.

STORAGE

If the tool is to be stored, or is idle for longer than 24 hours, run a few drops of CLARKE air line oil into the air inlet, and run the tool for 5 seconds in order to lubricate the internal parts.

Store the tool safely in its box in a dry, secure environment. When storing, replace the blanking plug on the airline inlet once the airline has been disconnected.

Avoid storing the air tool where the temperature is below 0°C.

MAINTENANCE



WARNING: MAKE SURE THAT THE AIR TOOL IS DISCONNECTED FROM THE AIR SUPPLY BEFORE STARTING ANY CLEANING, OR MAINTENANCE PROCEDURES.

DAILY

1. Before use, drain water from the airline filter and compressor.
2. If no line lubricator or mini oiler is used, ensure that oil is applied to the tool on a daily basis through the air inlet connection. Run a few drops of oil through the tool before use. It may be entered into the tool air inlet, (ensuring the strainer is clear), or into the hose at the nearest connection to the air supply. Only then should you operate the tool.
3. This procedure should be repeated after every two to three hours of use, or at the start of the working day.

WEEKLY

1. Check the air inlet screen filter for blockage and clean if necessary.

CLEANING

1. Keep the body of the tool clean and free from debris.
2. Grit or gum deposits in the tool may reduce efficiency.
3. After extensive use, remove the inlet screen filter and flush out the mechanism with gum solvent oil or an equal mixture of CLARKE air-line oil and paraffin. Allow to dry before use.
4. If the tool still runs erratically or becomes inefficient, and the air supply is of good quality, it may be necessary to dismantle the air motor and replace worn or damaged parts. You may prefer to take the tool to your CLARKE dealer if internal maintenance is required.

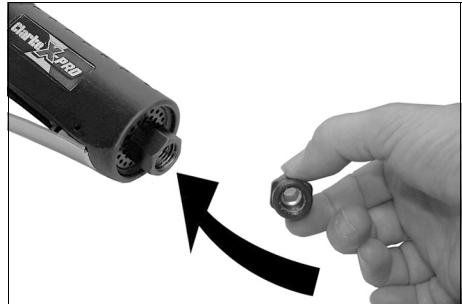

PERFORMANCE

Please note that outside factors may affect the tool's operation and efficiency such as reduced compressor output, excessive drain on the airline, moisture or restrictions in the air-line, or the use of connectors of improper size or poor condition which will reduce air supply.

Your CLARKE air tool has been designed to give long and trouble free service. If, however, having followed the instructions in this booklet carefully, you encounter problems, take the unit to your local CLARKE dealer.

TROUBLESHOOTING

SYMPTOM	PROBLEM	SOLUTION
Tool runs at normal speed but slows down under any load.	<ol style="list-style-type: none"> 1. Motor parts worn. 2. Worn or sticking mechanism due to lack of lubricant. 	<ol style="list-style-type: none"> 1. Return to CLARKE dealer for repair. 2. Drip air tool lubricating oil into air inlet. Allow oil to soak moving parts before using.
Tool runs slowly. Air flows weakly from exhaust.	<ol style="list-style-type: none"> 1. Motor parts jammed with gum/dirt. 2. Air-line regulator in closed position. 3. General airflow blocked by dirt. 	<ol style="list-style-type: none"> 1. Examine inlet air filter for blockage and clean if necessary. Drip a few drops of air tool lubricating oil into air inlet. 2. Adjust in-line regulator to open position. 3. Operate tool in short bursts.
Tool will not run. Air flows freely from exhaust.	<ol style="list-style-type: none"> 1. Motor vanes stuck due to buildup of foreign material. 	<ol style="list-style-type: none"> 1. Disconnect air supply and rotate tool assembly manually. 2. Try operating tool in short bursts. 3. Tap motor housing gently with a rubber mallet. 4. Drip a few drops of air tool lubricating oil into air inlet to soak moving parts.
Tool will not shut off.	<ol style="list-style-type: none"> 1. Throttle O-rings damaged or ill-fitting in seat. 	<ol style="list-style-type: none"> 1. Return to CLARKE dealer for repair.

PARTS LIST

No	Description
1	Main housing
2	Housing liner
3	Trigger
4	Bolt
5	O-ring
6	Bushing
7	O-ring
8	Valve stem
9	Spring
10	O-ring
11	Screw
12	Nipple
13	Exhaust deflector
14	Air inlet
15	Decoration ring
16	Bearing
17	Rear plate
18	Rotor
19	Rotor blade
20	Cylinder
21	Set pin
22	Front plate
23	Bearing
24	Cushion

No	Description
25	Ring gear
26	Gear
27	Gear Pin
28	Gear seat
29	Screw nut
30	Needle bearing
31	Bushing
32	Eccentric shaft
33	Drive bushing
34	Ratchet housing
35	Ratchet yoke
36	F/R knob
37	Sleeve
38	Spring
39	Washer
40	Ratchet head
41	Pin
42	Ratchet pawl
43	Washer
44	Circlip
45	Spring
46	Steel ball
47	Spring
48	Steel ball

PARTS DIAGRAM

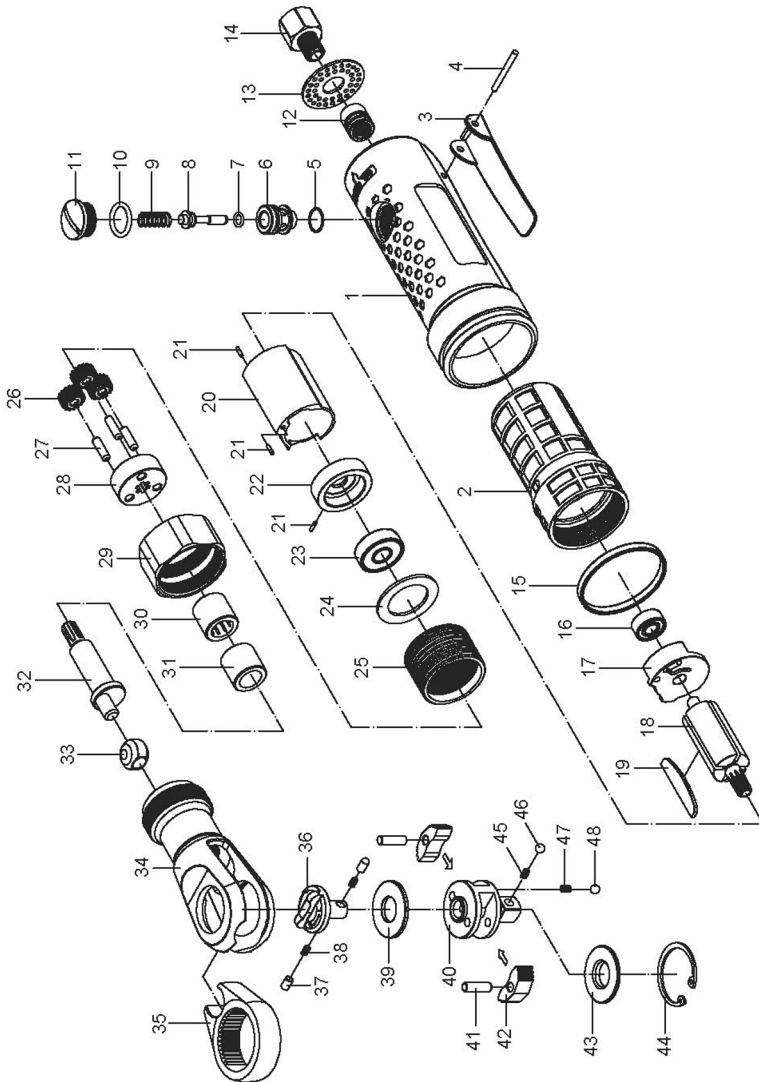

DECLARATION OF CONFORMITY



Clarke[®]
INTERNATIONAL
Fitzwilliam Hall, Fitzwilliam Place, Dublin 2

DECLARATION OF CONFORMITY

This is an important document and should be retained.

We hereby declare that this product(s) complies with the following directive(s):
2006/42/EC Machinery Directive.

The following standards have been applied to the product(s):
EN ISO 11148-6:2012.

The technical documentation required to demonstrate that the product(s) meet(s) the requirement(s) of the aforementioned directive(s) has been compiled and is available for inspection by the relevant enforcement authorities.

The CE mark was first applied in: 2019

Product Description: 1/2" Composite Air Ratchet Wrench
Model number(s): CAT199
Serial / batch Number: N/A
Date of issue: 09/02/2022

Signed:

J.A. Clarke
Director



Clarke[®]
INTERNATIONAL
Hemond Street, Epping, Essex CM16 4LG

DECLARATION OF CONFORMITY

This is an important document and should be retained.

We hereby declare that this product(s) complies with the following statutory requirement(s):
Supply of Machinery (Safety) Regulations 2008

The following standards have been applied to the product(s):
BS EN ISO 11148-6:2012

The technical documentation required to demonstrate that the product(s) meet(s) the requirement(s) of the aforementioned legislation has been compiled and is available for inspection by the relevant enforcement authorities.

The UKCA mark was first applied in: 2022

Product Description: 1/2" Composite Air Ratchet Wrench
Model number(s): CAT199
Serial / batch Number: N/A
Date of issue: 09/02/2022

Signed:

J.A. Clarke
Director

ACCESSORIES

A wide range of accessories is available including filter/regulators, lubricators, high-pressure hoses (5 to 50 metres) etc.

Contact your CLARKE dealer for further information or the Clarke International Service Department.

A wide range of 1/2" square drive socket sets is available in the CLARKE catalogue.

CLARKE Air Line Oil (part no. 3050825) is available from your CLARKE dealer.

GUARANTEE

This product is guaranteed against faulty manufacture for a period of 12 months from the date of purchase. Please keep your receipt which will be required as proof of purchase.

This guarantee is invalid if the product is found to have been abused or tampered with in any way, or not used for the purpose for which it was intended.

Faulty goods should be returned to their place of purchase, no product can be returned to us without prior permission.

This guarantee does not affect your statutory rights.

A SELECTION FROM THE VAST RANGE OF

Clarke®

QUALITY PRODUCTS



AIR COMPRESSORS

From DIY to industrial, Plus air tools, spray guns and accessories.

GENERATORS

Prime duty or emergency standby for business, home and leisure.

POWER WASHERS

Hot and cold, electric and engine driven - we have what you need

WELDERS

Mig, Arc, Tig and Spot. From DIY to auto/industrial.

METALWORKING

Drills, grinders and saws for DIY and professional use.

WOODWORKING

Saws, sanders, lathes, mortisers and dust extraction.

HYDRAULICS

Cranes, body repair kits, transmission jacks for all types of workshop use.

WATER PUMPS

Submersible, electric and engine driven for DIY, agriculture and industry.

POWER TOOLS

Angle grinders, cordless drill sets, saws and sanders.

STARTERS/CHARGERS

All sizes for car and commercial use.

PARTS & SERVICE:

0208 988 7400

Parts Enquiries

Parts@clarkeinternational.com

Servicing & Technical Enquiries

Service@clarkeinternational.com

SALES: UK 01992 565333 or Export 00 44 (0)1992 565335

Clarke INTERNATIONAL Hemnall Street, Epping, Essex CM16 4LG
www.clarkeinternational.com